



# FIRE - FIGHTING PUMPS & PACKAGES



UNI EN 12845 & UNI EN 12259-12



**AUDOLI & BERTOLA**  
a brand of

**Gruppo Aturia**



## HORIZONTAL Split-Case Type PDN-PD

FM Approved horizontal split-case type centrifugal fire pumps are relatively simple to operate and repair. These pumps have a two-part casing divided in a horizontal plane through the shaft center line. They are well suited to fire protection service where a water supply is obtainable under a positive head.

### CHARACTERISTIC PERFORMANCE RANGE

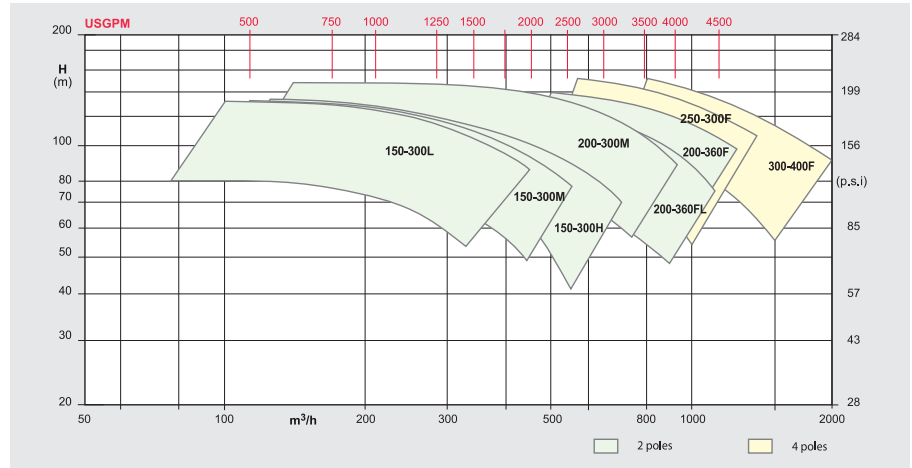

Type	Speed (R.P.M.)	Capacity (US G.P.M.)
PDN 150-300 L	2100 ÷ 3550	750 ÷ 1000
PDN 150-300 M	2100 ÷ 3550	1000 ÷ 1250
PDN 150-300 H	2100 ÷ 3550	1250 ÷ 1500
PDN 200-300 M	2350 ÷ 2970	2000
PD 200-250 B	1460 ÷ 1900	1250 ÷ 2000
PDN 200-360 F	2100 ÷ 2950	2500 ÷ 3000
PDN 200-360 FL	2950	2500 ÷ 3000
PDN 250-300 F	1490 ÷ 1800	2500 ÷ 3500
PDN 300-400 F	1490 ÷ 1800	3500 ÷ 4500

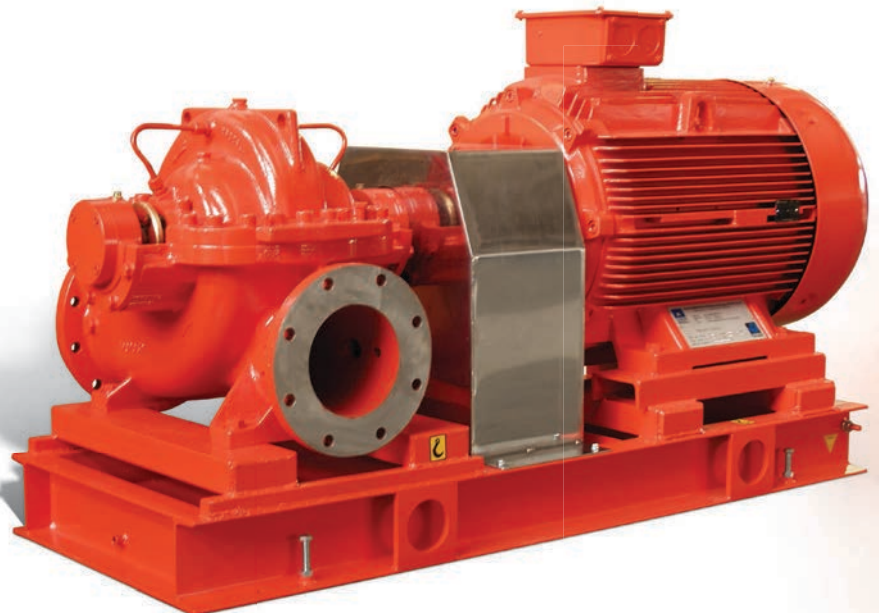

## PUMP DIMENSIONS

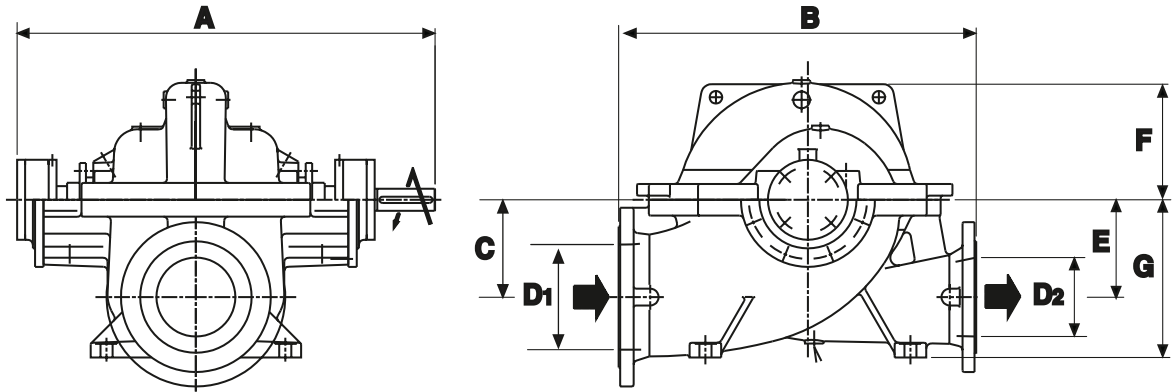

Pump	Dimension (mm)								Weight
	D <sub>1</sub>	D <sub>2</sub>	A	B	C	E	F	G	(kg)
PDN 150-300L	8"	6"	795	680	185	185	220	300	280
PDN 150-300M	8"	6"	795	680	185	185	220	300	280
PDN 150-300H	8"	6"	795	680	185	185	220	300	280
PDN 200-300M	10"	8"	795	760	200	200	237	350	330
PD 200-250B	10"	8"	1280	1030	285	335	460	470	900
PDN 200-360 F	10"	8"	925	850	225	225	270	370	600
PDN 200-360 FL	10"	8"	925	850	225	225	270	370	600
PDN 250-300 F	12"	10"	1230	980	350	350	350	550	950
PDN 300-400 F	16"	12"	1502	1300	360	360	415	620	1750

## SECTIONAL DRAWINGS

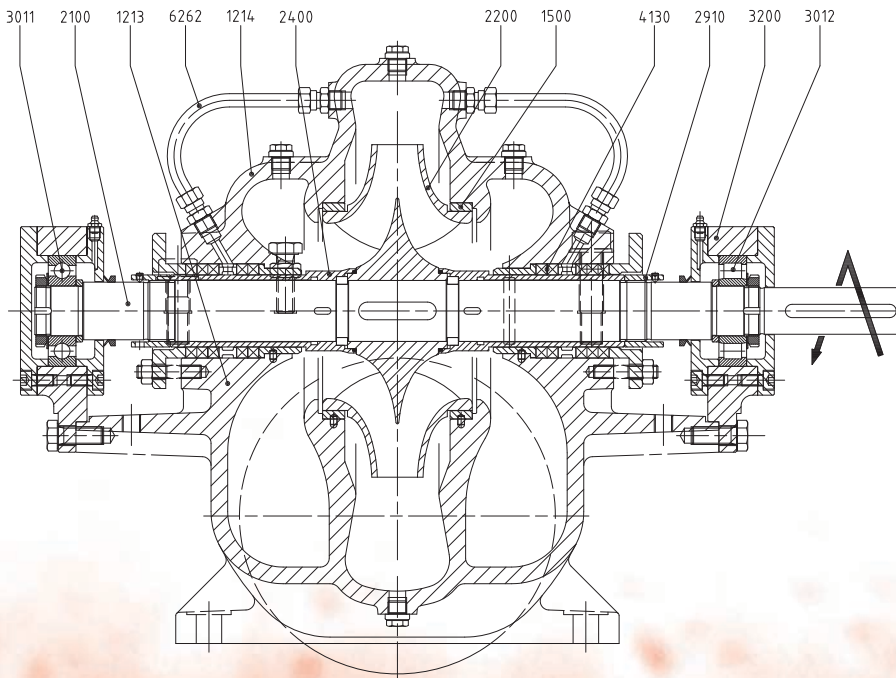

ref	DESCRIPTION	MATERIAL
1213	Casing half lower	Gray Iron ASTM A48 Class 40B
1214	Casing half upper	Gray Iron ASTM A48 Class 40B
1500	Casing wear ring	Tin Bronze ASTM B584 UNS 90500
2100	Shaft	Stainless Steel AISI 420
2200	Impeller	Aluminium Bronze ASTM B148 UNS C95200
2400	Sleeve	Bronze ASTM B427 UNS C90700
2910	Shaft nut	Bronze ASTM B427 UNS C90700
3011	Radial ball bearing	-
3012	Radial roller bearing	-
3200	Bearing housing	Gray Iron ASTM A48 Class 40B
4100	Staffing box	Tin Bronze ASTM B584 UNS 90500
4130	Gland packing	PTFE
4200	Mechanical seal	On requested
6262	Pipe	Stainless Steel

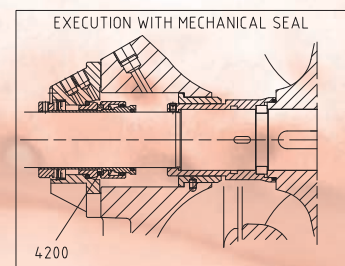



## VERTICAL Shaft, Turbine Type VAB



Vertical shaft, turbine type centrifugal fire pumps have submerged impellers contained in a series-bowl assembly at the bottom of a vertical shaft. The design is similar to pumps used extensively for industrial and municipal service. These pumps are FM Approved for discharging water from lakes, streams, open sumps, drilled wells and other equivalent subsurface sources. Each pump consists of a discharge head, motor stand, column pipe, line shaft, bowl assembly and suction strainer. For electric drive, FM Approved pumps must be used with a vertical, electric motor. For internal-combustion-engine drive, FM Approved pumps must be connected to the FM Approved engine through an FM Approved right-angle gear drive.



### CHARACTERISTIC PERFORMANCE RANGE

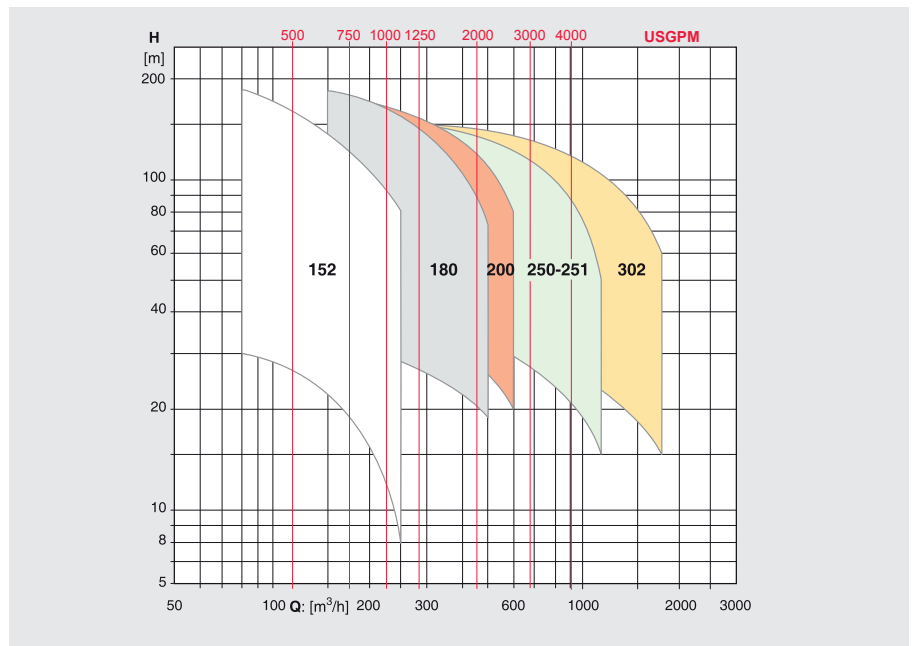

Type	Speed (R.P.M.)	Capacity (US G.P.M.)
VAB 152	1480 ÷ 1770	500 ÷ 750
VAB 180	1480 ÷ 1770	500 ÷ 1250
VAB 200	1480 ÷ 1770	1000 ÷ 1500
VAB 250	1480 ÷ 1770	1500 ÷ 2500
VAB 251	1480 ÷ 1770	2250 ÷ 3000
VAB 302	1480 ÷ 1770	2500 ÷ 4000

## SECTIONAL DRAWINGS

## PUMP DIMENSIONS

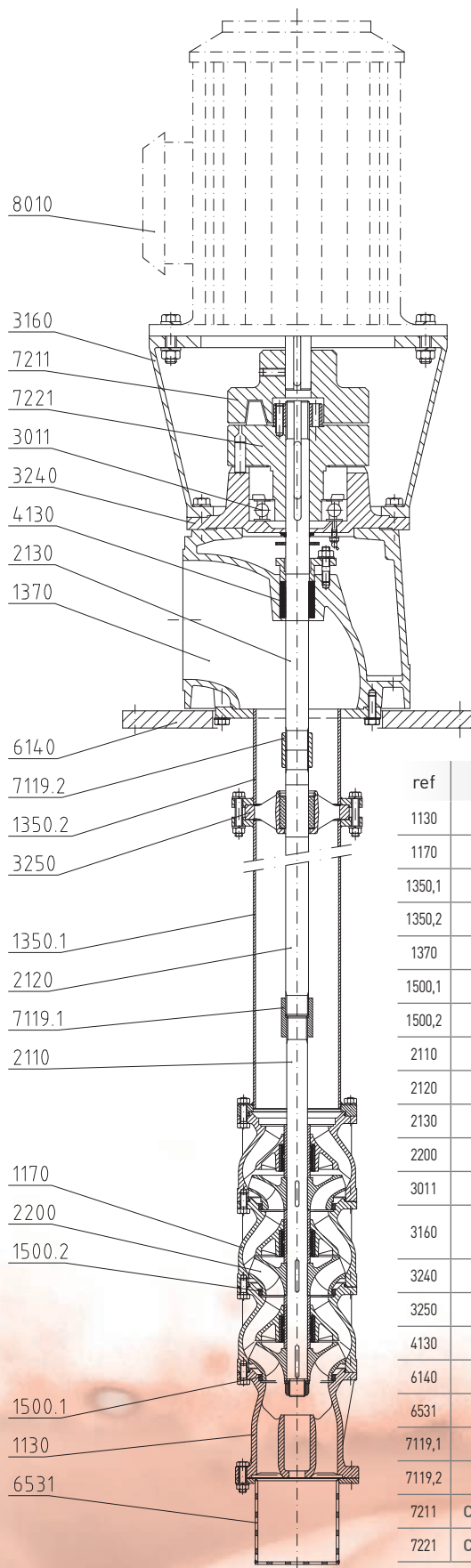

Type D (") D (mm)

152	12"	290
180	12"	300
200	14"	354
250	17"	418
251	17"	418
302	19"	480

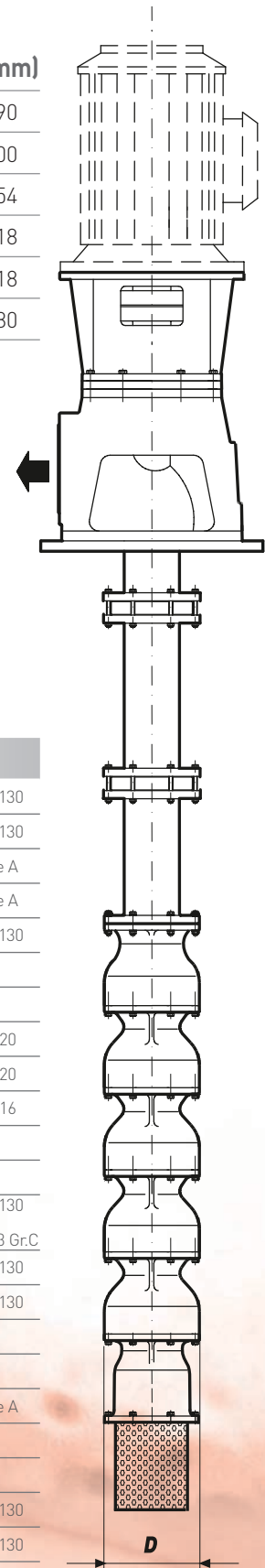

ref	DESCRIPTION	MATERIAL
1130	Bellmouth	Cast Iron ASTM A48 C130
1170	Pump Bowl	Cast Iron ASTM A48 C130
1350,1	Column Pipe	C.S. A53 Type S Grade A
1350,2	Column Pipe	C.S. A53 Type S Grade A
1370	Delivey Casing	Cast Iron ASTM A48 C130
1500,1	Wear Ring	Bronze SAE 65
1500,2	Wear Ring	Bronze SAE 65
2110	Pump Shaft	Stainless Steel AISI 420
2120	Intermediate Shaft	Stainless Steel AISI 420
2130	Top Shaft	Stainless Steel AISI 316
2200	Impeller	Bronze SAE 65
3011	Ball Bearing	Carbon Steel
3160	Motor Stool	Cast Iron ASTM A48 C130 (up to 280 kW) Carbon Steel ASTM A283 Gr.C
3240	Bearing Housing	Cast Iron ASTM A48 C130
3250	Bearing Bracket	Cast Iron ASTM A48 C130
4130	Gland Packing	Teflon - Carbon
6140	Foundation Plate	C.S. Fe 430
6531	Suction Strainer	C.S. A53 Type S Grade A
7119,1	Screwed Coupling	S.S. AISI 420
7119,2	Screwed Coupling	S.S. AISI 420
7211	Coupling Half Side Motor	Cast Iron ASTM A48 C130
7221	Coupling Half Side Pump	Cast Iron ASTM A48 C130

# TYPICAL INSTALLATION OF FIRE-FIGHTING SETS WITH HORIZONTAL PUMPS

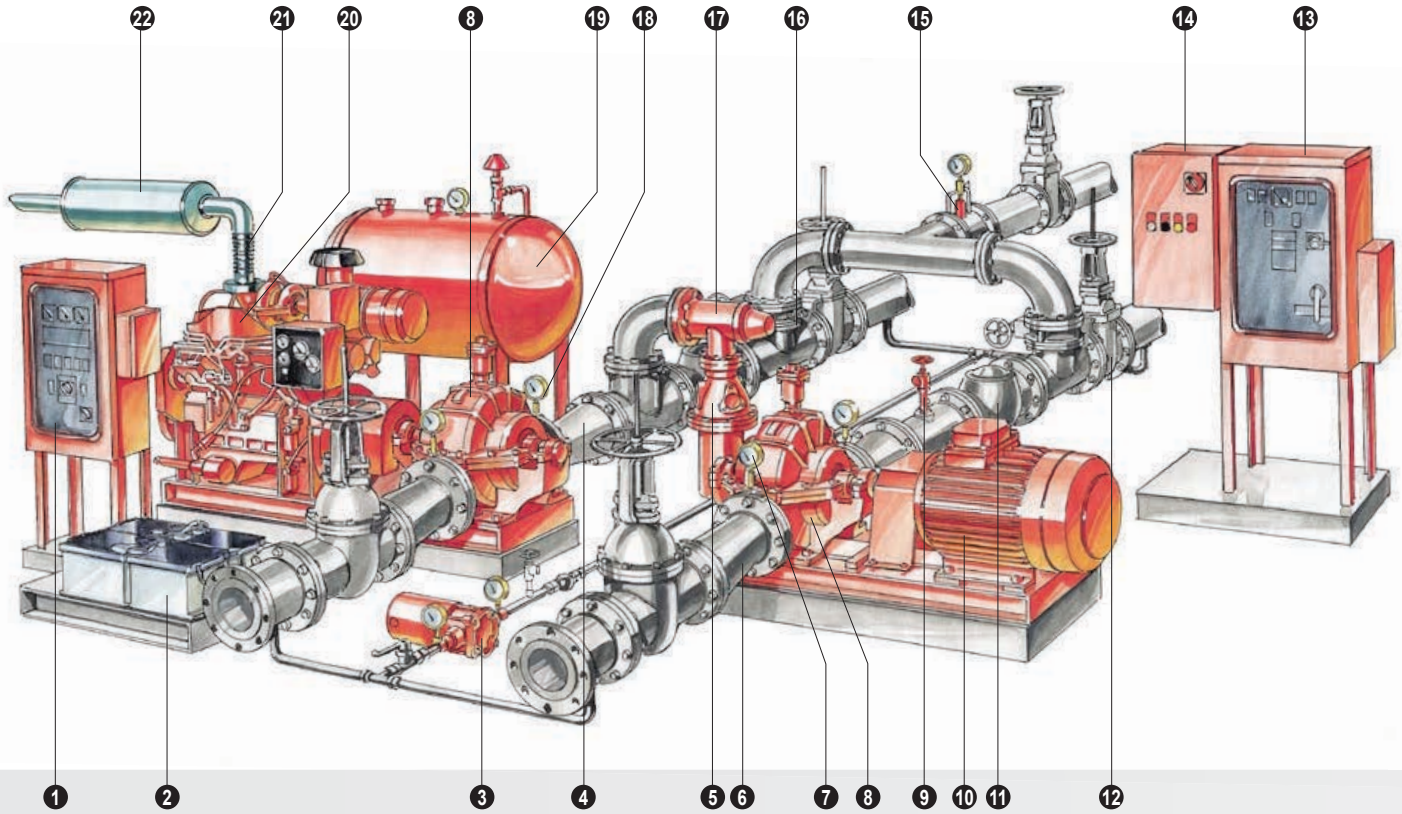

- 1\_Diesel engine fire pump controller
- 2\_Batteries
- 3\_Jockey pump
- 4\_Concentric discharge increaser
- 5\_Enclosed discharge overflow cone
- 6\_Eccentric suction reducer
- 7\_Suction pressure gauge
- 8\_Horizontal pump
- 9\_Circulation relief valve
- 10\_Electric motor
- 11\_Check valve
- 12\_OS& Y gate valve
- 13\_Electric motor fire pump controller
- 14\_Jockey pump controller
- 15\_Tlow est fmeter
- 16\_Automatic air release valve
- 17\_Main relief valve
- 18\_Discharge pressure gauge
- 19\_Fuel tank
- 20\_Diesel engine
- 21\_Flexible exhaust connector
- 22\_Exhaust muffler

HORIZONTAL FIRE PUMPS DIESEL ENGINE DRIVEN, F.M./U.L. APPROVED RANGE

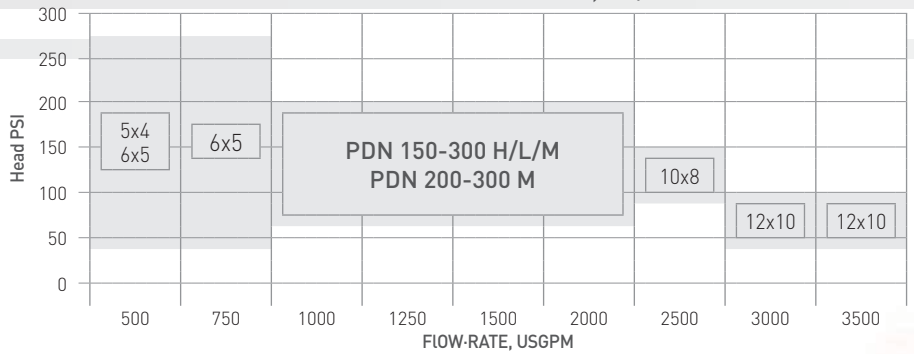

HORIZONTAL FIRE PUMPS ELECTRIC MOTOR DRIVEN, F.M./U.L. APPROVED RANGE

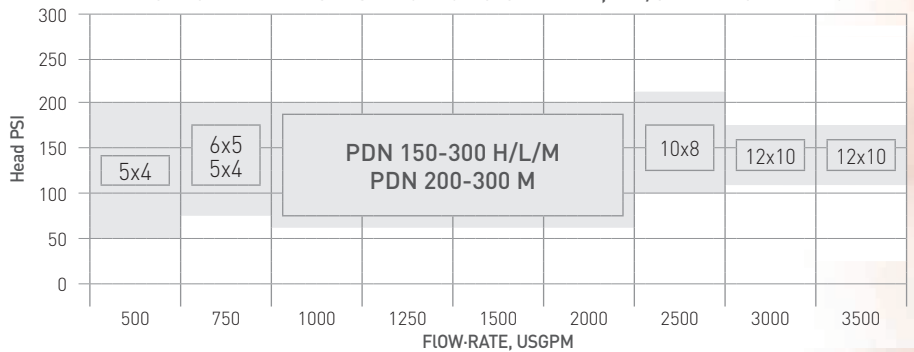

# TECHNICAL SPECIFICATION FOR HORIZONTAL FIRE PUMPS COMPLY TO NFPA 20 AND/OR FACTORY MUTUAL STANDARDS

The set supplied by Audoli & Bertola for fire-fighting service shall include the Pump, driver, controller and fittings in the following technical specifications. The set shall be manufactured according to the standards of the "National Fire Protection Association", section 20.

The materials shall be:

- Factory Mutual Research Corporation (FM) approved
- Underwriters Laboratories (UL) (ULC) listed specifically for fire-fighting service.

All the materials supplied shall be installed as recommended in NFPA 20.

## TEST PERFORMED BY THE MANUFACTURER

Each pump shall be subjected to a hydrostatic test of at least 5 minutes, at a pressure not less than 1.5 times the shut-off head plus maximum suction head and at any event, at a pressure not lower than 250 PSI.

The pump shall be able to deliver 150% of the nominal flow at no less than 65% of head at the working point, and the shut off head shall not exceed 140% of the rated head.

## FIELD TESTS

A field test shall be performed by a suitable flow measuring device.

The test shall be conducted to NFPA 20, by:

- the installer
- the Audoli & Bertola engineer
- at the presence of authority responsible for acceptance release.

## HORIZONTAL CENTRIFUGAL PUMP

The type \_\_\_\_\_ fire fighting pump, dimensioned according to NFPA 20 shall be

- Factory Mutual Research Corporation (FM) approved
- Underwriters Laboratories (UL) (ULC) listed for the following performance ratings:

Q \_\_\_\_\_ m<sup>3</sup>/h \_\_\_\_\_ USGPM \_\_\_\_\_  
H \_\_\_\_\_ m \_\_\_\_\_ PSI \_\_\_\_\_ RPM \_\_\_\_\_  
Suction pressure: \_\_\_\_\_ Bar \_\_\_\_\_ PSI \_\_\_\_\_

Suction pressure at the pump flange shall be not be less than "0 PSI" at 150% of flow conditions.

The fire-fighting pump shall be:

- split case type
- end suction type (DIN 24255)

construction: cast-iron casing and bronze impeller.

packing seal with sleeves (s) of  bronze  stainless steel

Suction flange Dn \_\_\_\_\_ PN \_\_\_\_\_/\_\_\_\_\_ " ANSI \_\_\_\_\_ #

Discharge flange Dn \_\_\_\_\_ PN \_\_\_\_\_/\_\_\_\_\_ " ANSI \_\_\_\_\_ #

## ELECTRIC MOTOR

The electric motor shall be horizontal foot mounted B3 type, powered at \_\_\_\_\_ V, 3-phase, 50 hz, with rated power of \_\_\_\_\_ kW, with IP 55 protection and F insulation class.

The electric motor shall be mounted on a steel base common to the pump and shall coupled to the pump by means of an elastic coupling equipped with a suitable coupling guard.

The pump and the motor shall be carefully aligned in the workshop.

Correct alignment shall be verified in the field, before the tests, by skilled technicians.

## ELECTRIC MOTOR FIRE PUMP CONTROLLER

The automatic start control panel shall conform to NFPA 20 stds. and shall be

- Factory Mutual Research Corporation (FM) approved.
- Underwriters Laboratories (UL) (ULC) listed for fire-fighting service.

The controller shall be:

- D.O.L. starting type
- Star delta starting type

The controller, of suitable size for the power installed, shall be dimensioned for an interrupting capacity rating of at least 30 kA RMS sym.

It shall be designed for:

- wall (standard) mounted
- floor mouted
- mounted on a common base plate with pump and the motor, with anti-vibration blocks and electric wiring.

## DIESEL ENGINE

The diesel engine shall be horizontal type, comply to NFPA 20 and

Factory Mutual Research Corporation (FM) approved.

Underwriters Laboratories (IL) (ULC) listed

Manufacturer \_\_\_\_\_ Model \_\_\_\_\_

power rated kW \_\_\_\_\_ RPM \_\_\_\_\_

clockwise rotation view from flywheel opposite side.

- water cooled with radiator and fan.
- water cooled with heat exchanger of water cooling circuit in accordance with NFPA 20, consisting of: 4 shut-off valves, 1 pressure regulator valve, 1 pressure gauge, 1 on-off solenoid valve, 2 "Y" strainers, 1 by-pass circuit.

Fitting available:

- Silencer with flexible connection  industrial  residential
  - Set of dual batteries  lead acid  NiCd type
- complete with rack and cables and electrolyte, shipped in separate containers.
- Fuel tank, of \_\_\_\_\_ litre capacity, dimensioned to contain 1 gallon of fuel for each maximum engine power HP, plus 10% for sump and expansion area, complete with the following accessories: filler plug, drain valve, feed valve and filter, flame arrest, flexible hoses connection to the engine, visual level indicator, low fuel level switch and supports for floor mounting.
  - Engine jacket water heater
  - Instrument panel aboard the engine
  - Overspeed device
  - Emergency contactors.

## DIESEL ENGINE PUMP CONTROLLER

The Automatic controller shall conform to NFPA 20 and shall be

Factory Mutual Research Corporation (FM) approved.

Underwriters Laboratories (IL) (ULC) listed

specifically for fire-fighting service.

The controller shall be 220 operating volts, single phase, 50hz, and shall be

equipped with following minimum accessories:

double battery charger, timer for weekly test and discharge solenoid valve, starting pressure switch, pressure recorder, low fuel level alarm.

It shall be designed to be positioned:

- wall (standard) mounted
- floor mounted
- mounted on a common base plate and the motor, with anti-vibration blocks and electric wiring,

## ACCESSORIES

The following shall be supplied in accordance with NFPA 20:

- 1/2" automatic air release valve
  - (Ø3 1/2 - 16 bar) suction and discharge pressure gauge
  - circulation relief valve (electric pump)  3/4"  1"
  - main relief valve  3"  4"  6"  8"
  - enclosed waste cone with glass  3"x5"  4"x8"  6"x10"  8"x12"
  - hose valve test header  4"  6"  8"  10"
- complete with  2  3  4  6  8
- 2 1/2" hose valves with caps and chain  4"  5"  6"  8"  10"
- flow test meter

# TYPICAL INSTALLATION OF FIRE-FIGHTING SETS WITH VERTICAL

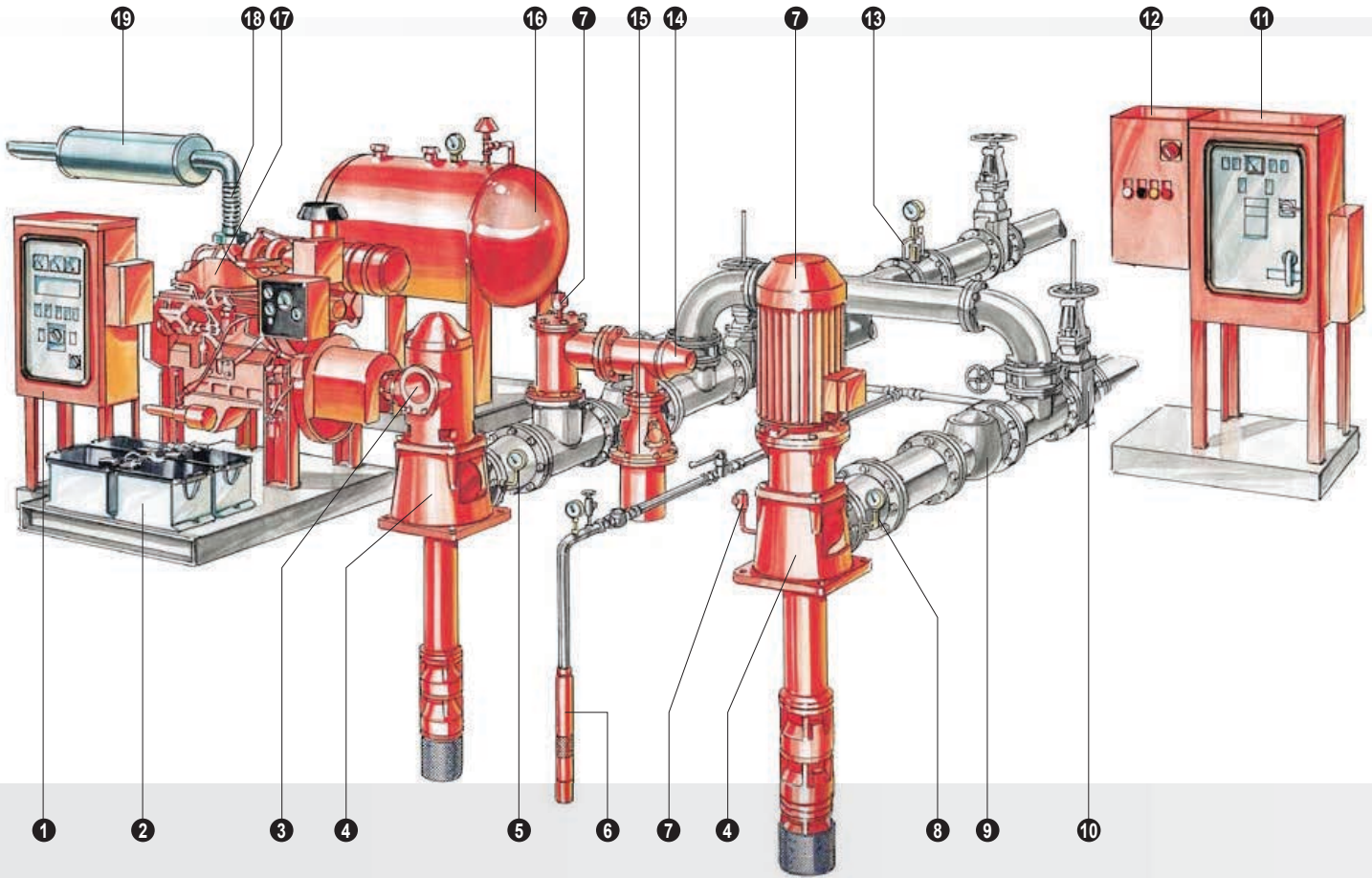

VERTICAL PUMPS AT 1n0 RPM, F. M. APPROVED RANGE HEAD. PSI FLOW-RATE USGPM

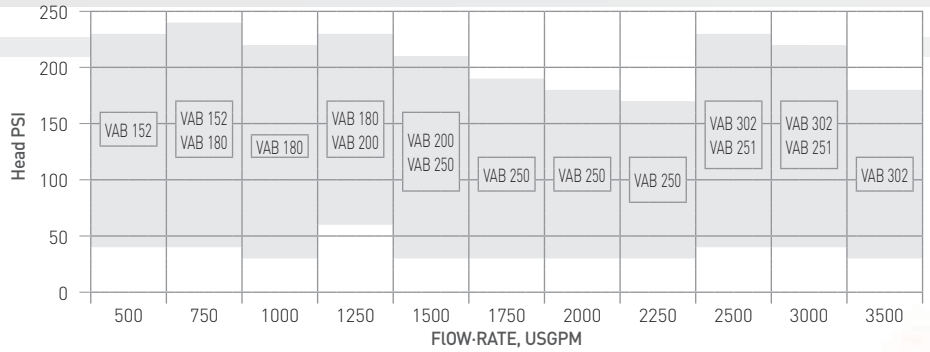

- 1\_Diesel engine fire pump controller
- 2\_Batteries
- 3\_Right angle gear
- 4\_Verticle turbine pump
- 5\_Discharge pressure gauge
- 6\_Jockey pump
- 7\_Automatic air release valve
- 8\_Concentric discharge increaser
- 9\_Check valve
- 10\_OS & Y gate valve
- 11\_Electric motor controller
- 12\_Jockey pump controller
- 13\_Test flow meter
- 14\_Main relief valve
- 15\_Open discharge overflow cone
- 16\_Fuel tank
- 17\_Diesel engine
- 18\_Flexible exhaust connection
- 19\_Exhaust muffler

VERTICAL PUMPS AT 1n0 RPM, F. M. APPROVED RANGE HEAD. PSI FLOW-RATE USGPM

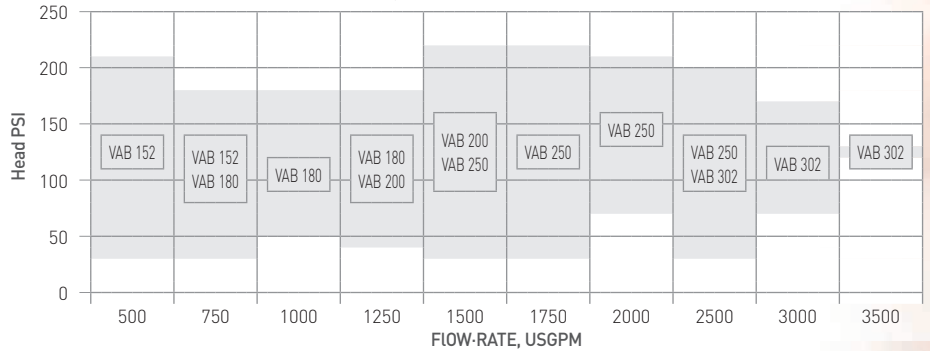

# TECHNICAL SPECIFICATION FOR VERTICAL FIRE PUMPS COMPLY TO NFPA 20 AND/OR FACTORY MUTUAL STANDARDS

The set supplied by Audoli & Bertola for fire-fighting service shall include the Pump, driver, controller and fittings in the following technical specifications. The set shall be manufactured according to the standards of the "National Fire Protection Association", section 20.

The materials shall be:

- Factory Mutual Research Corporation (FM) approved
- Underwriters Laboratories (UL) (ULC) listed specifically for fire-fighting service.

All the materials supplied shall be installed as recommended in NFPA 20.

## TEST PERFORMED BY THE MANUFACTURER

Each pump shall be subjected to a hydrostatic test of at least 5 minutes, at a pressure not less than 1.5 times the shut-off head plus maximum suction head and at any event, at a pressure not lower than 250 PSI.

The pump shall be able to deliver 150% of the nominal flow at no less than 65% of head at the working point, and the shut off head shall not exceed 140% of the rated head.

## FIELD TESTS

A field test shall be performed by a suitable flow measuring device.

The test shall be conducted to NFPA 20, by:

- the installer
- the Audoli & Bertola engineer
- at the presence of authority responsible for acceptance release.

## VERTICAL TURBINE PUMP

The type \_\_\_\_\_ fire fighting pump, dimensioned according to NFPA 20 shall be

- Factory Mutual Research Corporation (FM) approved
- Underwriters Laboratories (UL) (ULC) listed for the following performance ratings:

Q \_\_\_\_\_ m<sup>3</sup>/h \_\_\_\_\_ USGPM \_\_\_\_\_  
H \_\_\_\_\_ m \_\_\_\_\_ PSI \_\_\_\_\_ RPM \_\_\_\_\_

Length of pump from base plate/ strainer \_\_\_\_\_ mm  
Minimum submergence \_\_\_\_\_ m at 150% of nominal flow.

The fire-fighting pump shall be made casing and discharge head head of cast-iron, bronze impellers, stainless steel strainer and gland packing with hard chromed shaft sleeve.

Discharge flange Dn \_\_\_\_\_ PN \_\_\_\_\_ / \_\_\_\_\_" \_\_\_\_\_ ANSI \_\_\_\_\_ #

Pump head construction:

- 90° right angle gear drive
- vertical hollow shaft motor (NEMA)
- solid shaft electric motor (IEC-UNELL-MEC)

The column line shall be:

- open line shaft water lubricated by the pumped liquid
- enclosed line oil lubricated (static water level > 15 m).

## ELECTRIC MOTOR

The electric motor shall be vertical V1 type or horizontal foot mounted B3 type, powered at \_\_\_\_\_ V, 3-phase, 50 hz, with rated power of \_\_\_\_\_ kW, with IP 55 protection and F insulation class.

Starting current shall not exceed the values specified in NFPA 20.

The electric motor shall be installed:

- directly mounted on discharge head complete with bearings and anti-rotation device.
- on a separate steel base, and connected to the pump by means an elastic coupling or cardan shaft, protected by a suitable joint cover. Correct alignment shall be verified in the field, before the tests, by skilled technicians.

## RIGHT ANGLE GEAR

The hollow shaft angle gear shall be fitted directly to the pump head and shall contain both the thrust bearings and the anti-rotation device. It shall be comply to the NFPA 20 standards with 1.5 AGMA service factor, and shall be

- Factory Mutual Corporation (FM) approved.

## ELECTRIC MOTOR FIRE PUMP CONTROLLER

The automatic start control panel shall conform to NFPA 20 stds. and shall be

- Factory Mutual Research Corporation (FM) approved.
- Underwriters Laboratories (IL) (ULC) listed for fire-fighting service.

The controller shall be:

- D.O.L. starting type
- Star delta starting type

The controller, of suitable size for the power installed, shall be dimensioned for an interrupting capacity rating of at least 30 kA RMS sym.

It shall be designed for:

- wall (standard) mounted
- floor mouted
- mounted on a common base plate with pump and the motor, with anti-vibration blocks and electric wiring.

## DIESEL ENGINE

The diesel engine shall be horizontal type, comply to NFPA 20 and

- Factory Mutual Research Corporation (FM) approved.
- Underwriters Laboratories (IL) (ULC) listed

Manufacturer \_\_\_\_\_ Model \_\_\_\_\_  
power rated kW \_\_\_\_\_ RPM \_\_\_\_\_

clockwise rotation view from flywheel opposite side.

water cooled with radiator and fan.

- water cooled with heat exchanger of water cooling circuit in accordance with NFPA 20, consisting of: 4 shut-off valves, 1 pressure regulator valve, 1 pressure gauge, 1 on-off solenoid valve, 2 "Y" strainers, 1 by-pass circuit.

Fitting available:

- Silencer with flexible connection  industrial  residential
- Set of dual batteries  lead acid  NiCd type
- complete with rack and cables and electrolyte, shipped in separate containers.
- Fuel tank, of \_\_\_\_\_ litre capacity, dimensioned to contain 1 gallon of fuel for each maximum engine power HP, plus 10% for sump and expansion area, complete with the following accessories: filler plug, drain valve, feed valve and filter, flame arrest, flexible hoses connection to the engine, visual level indicator, low fuel level switch and supports for floor mounting.
- Engine jacket water heater
- Instrument panel aboard the engine
- Overspeed device
- Emergency contactors.

## DIESEL ENGINE PUMP CONTROLLER

The Automatic controller shall conform to NFPA 20 and shall be

- Factory Mutual Research Corporation (FM) approved.
- Underwriters Laboratories (IL) (ULC) listed

specifically for fire-fighting service.

The controller shall be 220 operating volts, single phase, 50hz, and shall be equipped with following minimum accessories:

double battery charger, timer for weekly test and discharge solenoid valve, starting pressure switch, pressure recorder, low fuel level alarm.

It shall be designed to be positioned:

- wall (standard) mounted
- floor mounted
- mounted on a common base plate and the motor, with anti-vibration blocks and electric wiring,

## ACCESSORIES

The following shall be supplied in accordance with NFPA 20:

- 1/2" automatic air release valve
- (Ø3 1/2 - 16 bar) suction and discharge pressure gauge
- circulation relief valve (electric pump)  3/4"  1"
- main relief valve  3"  4"  6"  8"
- enclosed waste cone with glass  3"x5"  4"x8"  6"x10"  8"x12"
- hose valve test header  4"  6"  8"  10"
- complete with  2  3  4  6  8
- 2 1/2" hose valves with caps and chain
- flow test meter  4"  5"  6"  8"  10"



## FIRE- FIGHTING Pumping Systems



With "Audoli&Bertola" Division, Gruppo Aturia operates in the firefighting field as supplier of water fire fighting packages fully in compliance with the European Standards (EN 12845 e EN 12259-12) and the American Standards (NFPA 20). Audoli&Bertola technical skill allows to easily operate in building and industrial fields and to meet the hardest specifications required by refineries, petrochemical industries and off-shore. Gruppo Aturia offers a wide range of centrifugal pumps for fire fighting application, both in vertical and in horizontal construction. Audoli&Bertola is the only Italian pumps manufacturer to have obtained from "Factory Mutual" the approval for its vertical turbine pumps and split case pumps for a range of capacities from 500 USGPM to 3500 USGPM, at 50 ÷ 60 Hz and Diesel Driven.

ATEX: Packages and Pumps for ATEX Classified area are available for Electrical Pump and Diesel Engine Driven Pump Fire-Fighting services.

### SPLIT CASE PUMPS TYPICAL INSTALLATIONS

#### IMPROVING WORKFORCE EFFICIENCY:

Standard factory certifications improve worksite safety

- Class I Division 2 (NEC 500)
- Class I Zone 2 (NEC 505)
- ATEX Directive (94/9/EC) Group II
- 3G Environments (Zone 2) with Gas Group T3
- Electrical IIC and Temperature Class T3

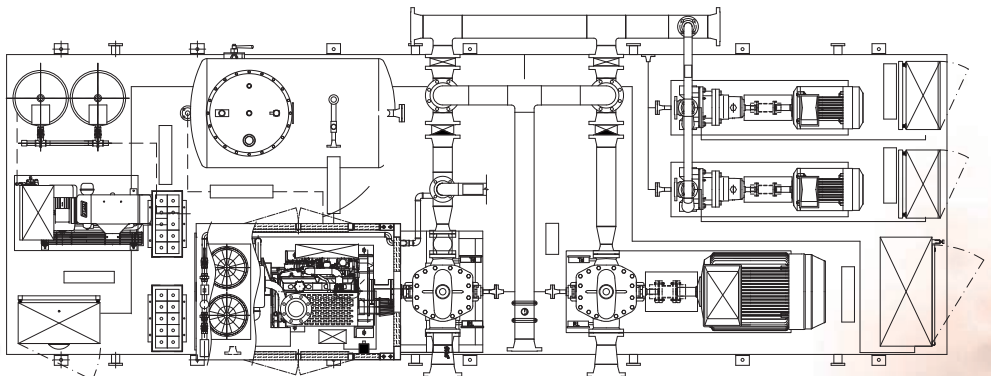
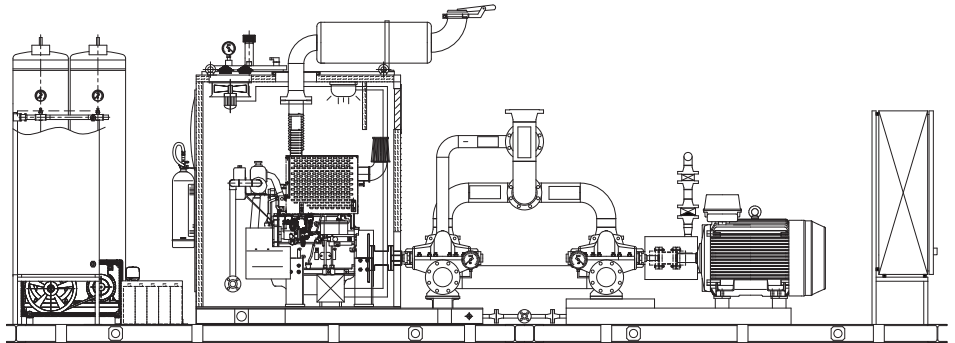

# VERTICAL PUMPS TYPICAL INSTALLATIONS

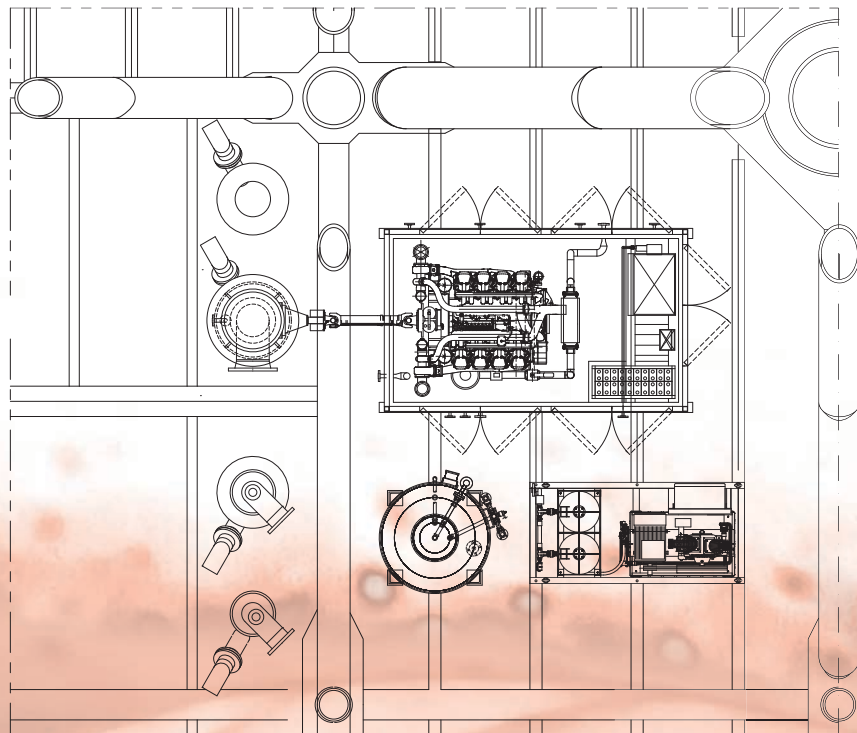
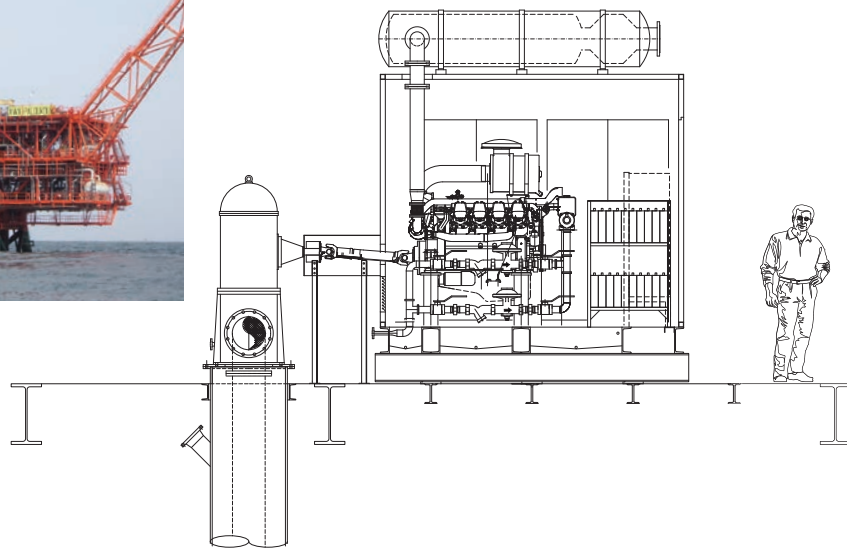



## SOME REFERENCES

Ansaldo Energia  
Saipem  
Snamprogetti  
Edison  
Danieli  
Holzhauer  
Abb  
Eni  
Mondadori  
Techint  
Silvani  
Antibioticos

Sonatrach  
Petrofac  
Saint-Gobain  
Nuovo Pignone (Generale  
Electric)  
Tecnimont  
Rigel  
Nuovo Pignone  
Rosetti Marino  
Comau  
Polibrasil  
Seda

Technip  
Ecis Group  
Wormald Ltaliana  
Foster Wheeler  
Fiat  
Johnson Controls  
Siemens  
Sud Progetti  
Riccardi  
Samir Refinery  
Irasco  
Piping Engineering Constr

Progetti Europa & Global  
Berger  
Danway  
Siraga  
Fisia Italimpianti  
British Gas Tunisia  
Shell  
Murphy  
A.m.general Contractor  
Rahmat Dagangan  
Enka Teknik

liberati@v.com



A highly efficient servicing organizations, a periodical maintenance service and prompt availability of spare parts are the means adopted by "Audoli & Bertola" to offer its customers a fully satisfactory after-sales service.

Thanks to the "Periodical Technical Servicing Facility - S.A.T.P.", all "Audoli & Bertola" customers may rest secured that the high degree of safety and efficiency of the components will remain unchanged through time.

The periodical checks performed by the "S.A.T.P.", in fact, make it possible to identify and remedy possible anomaly, thereby preventing repair costs from soaring and ensuring long-term service efficiency, necessary to guarantee safety against fires.

### Contacts:

Assistance: +39 011 2250759 - After-Sales Service: +39 011 2250790

Switchboard Tel. +39 011 2250711 - Fax +39 011 2250700

Corso Romania 501/18 - 10156 Torino

mail:[info@audolibertola.com](mailto:info@audolibertola.com)

### Gruppo Aturia



20060 Gessate (MI) - ITALY - Piazza Aturia 9 - Tel. +39 02 95423200 - Fax +39 02 95423202

10156 Torino - ITALY - Corso Romania 501/18

45019 Taglio di Po (Rovigo) - ITALY - Via dell'Industria 4

[www.gruppoaturia.com](http://www.gruppoaturia.com)

05-15/6005 E